

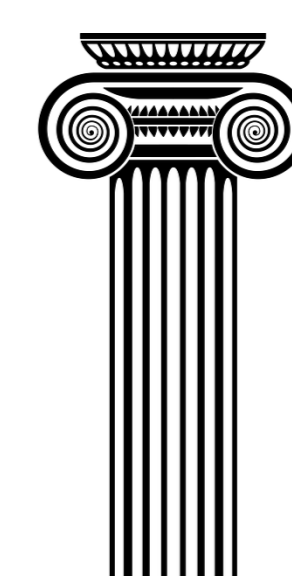

## Union of Light Ion Centres in Europe

The ULICE project was launched in September 2009 and is coordinated by the National Centre for Oncological Hadrontherapy (CNAO) in Pavia, Italy. ULICE responds to the need for greater access to hadrontherapy facilities for both research and clinical use.

The project is funded for 5 years by the EC with 8.4M Euros, and involves 20 European institutes including, 2 leading industrial partners.

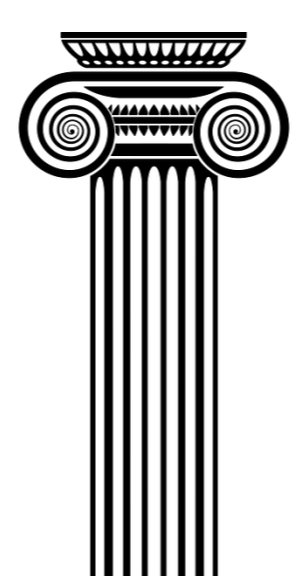
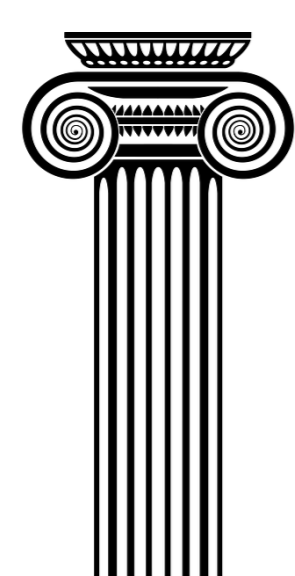

### Joint Research Activities

- Coordinated by Medical University of Vienna.
- Aims at improving the performance of hadron therapy facilities by research and development
  - New gantry design
  - Development of instruments
  - Adaptive treatment planning
  - Computer assisted patient selection program

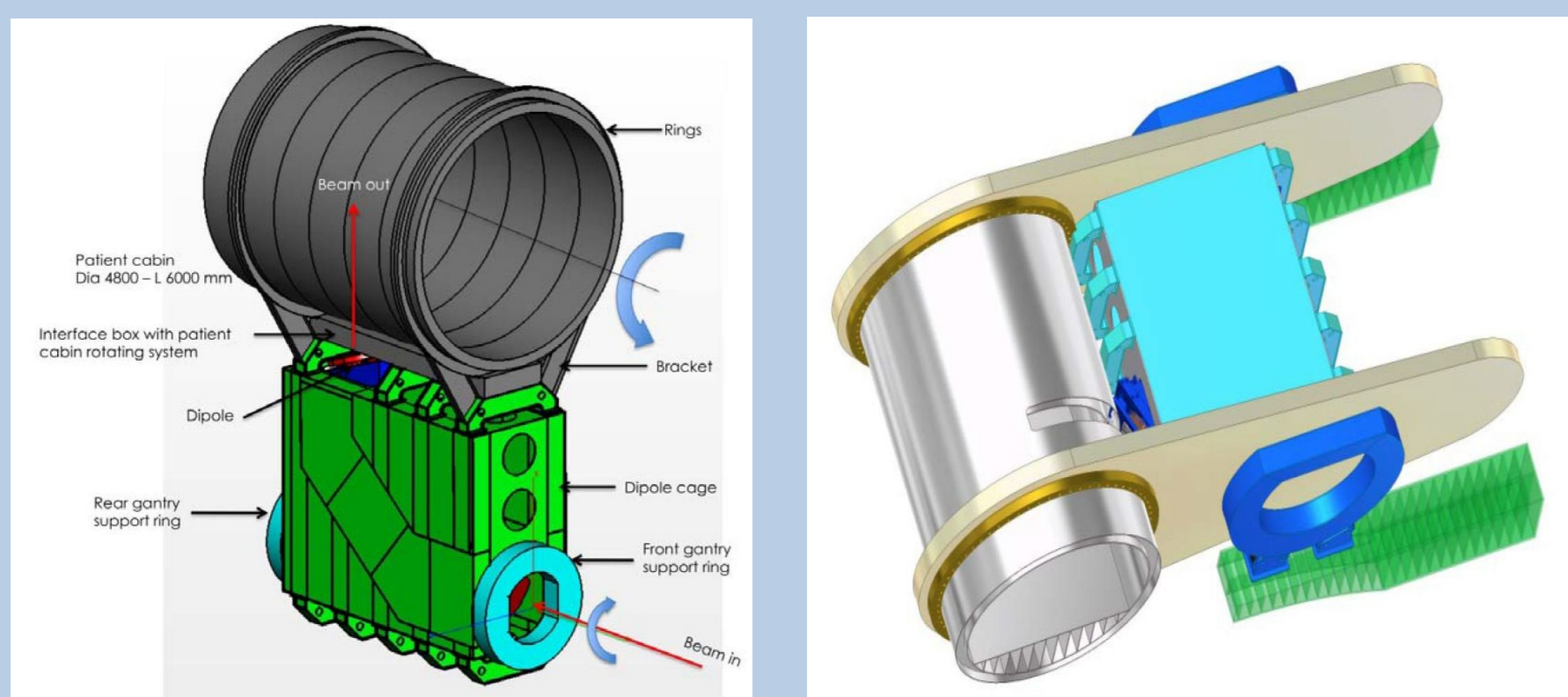

### Transnational access

- Coordinated by University Hospital of Heidelberg
- Beam time access provided for clinical trials and experimental research at two recently opened dual-ion facilities – HIT and CNAO

An extra year to apply for beam time.  
ULICE extended by 12 months to end of August 2014

#### WATCH OUR VIDEO

Following up from the last issue of Highlights, a video on transnational access has been produced.

WATCH OUR VIDEO OVER AT:  
[HTTP://CDS.CERN.CH/RECORD/1475404](http://cds.cern.ch/record/1475404)



### Networking Activities

- Coordinated by CERN
- Communication and dissemination among the 20 partners and with the external world
- One-month training courses at HIT and CNAO
- Project brochure
- Videos and articles

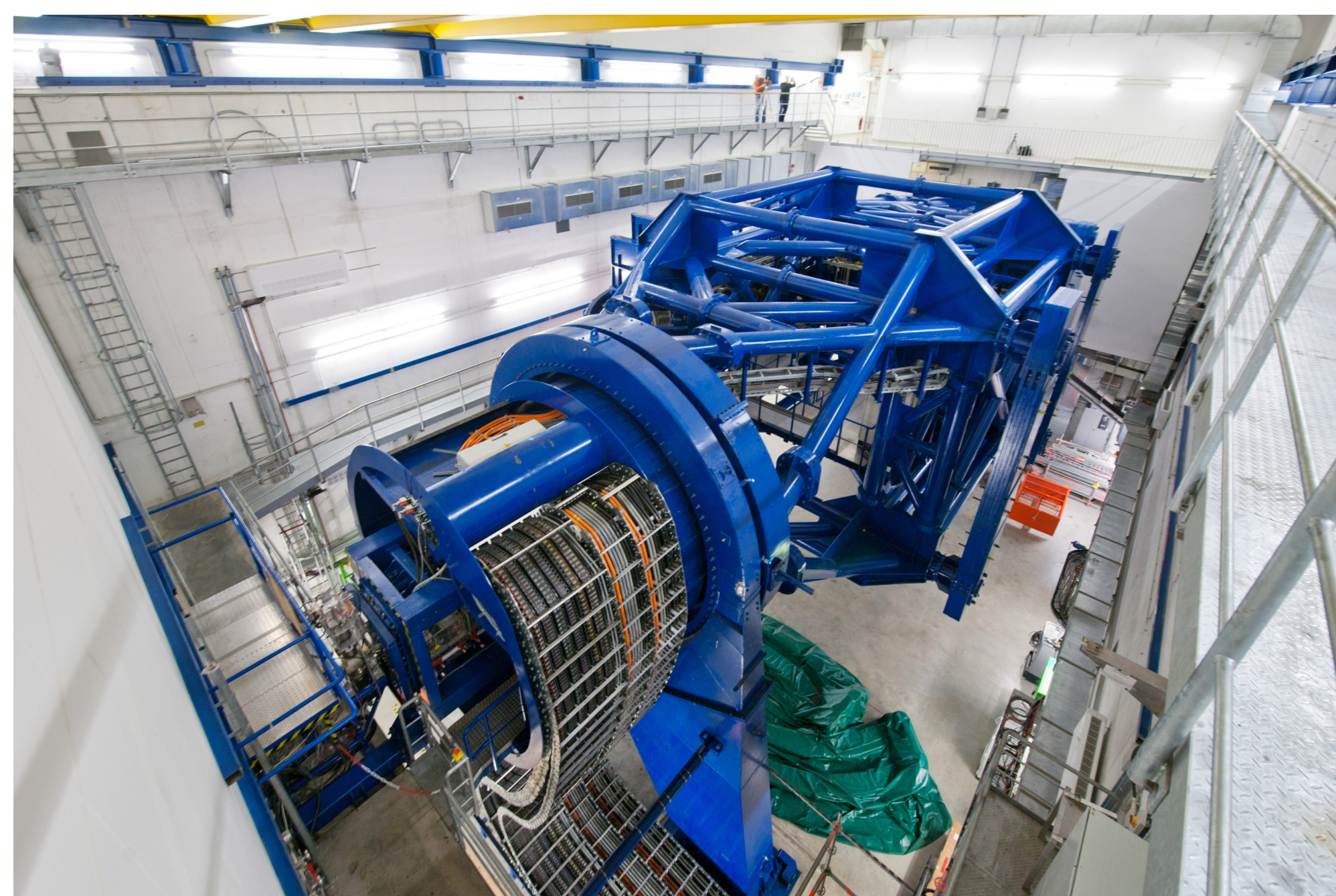
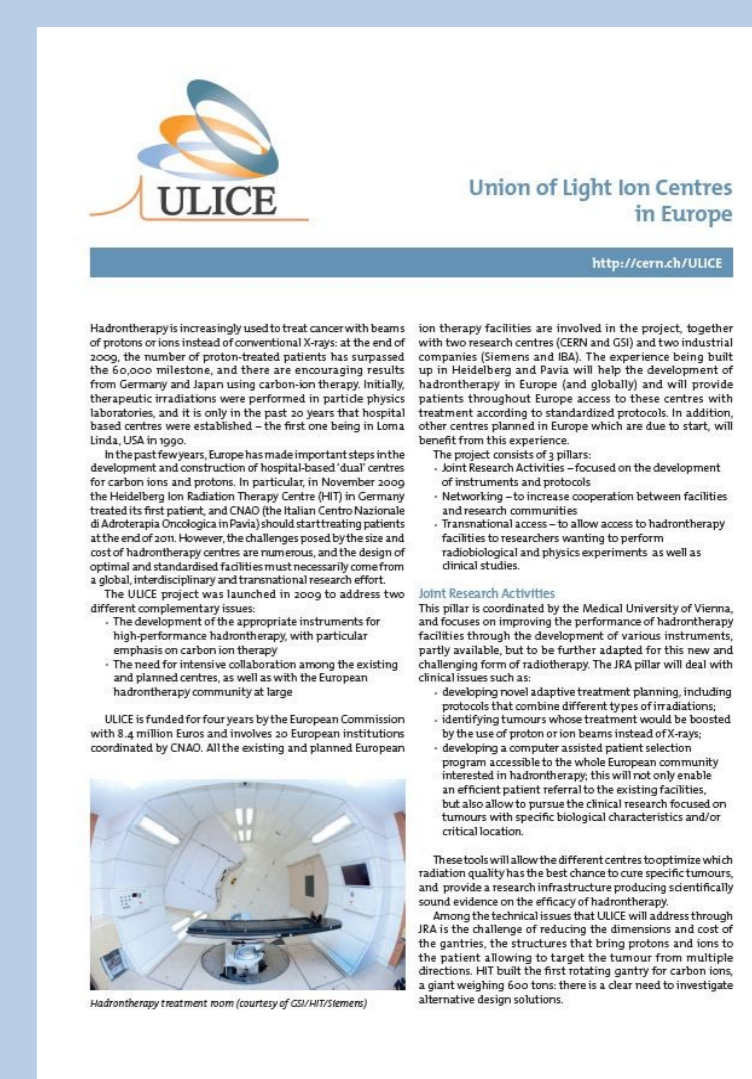
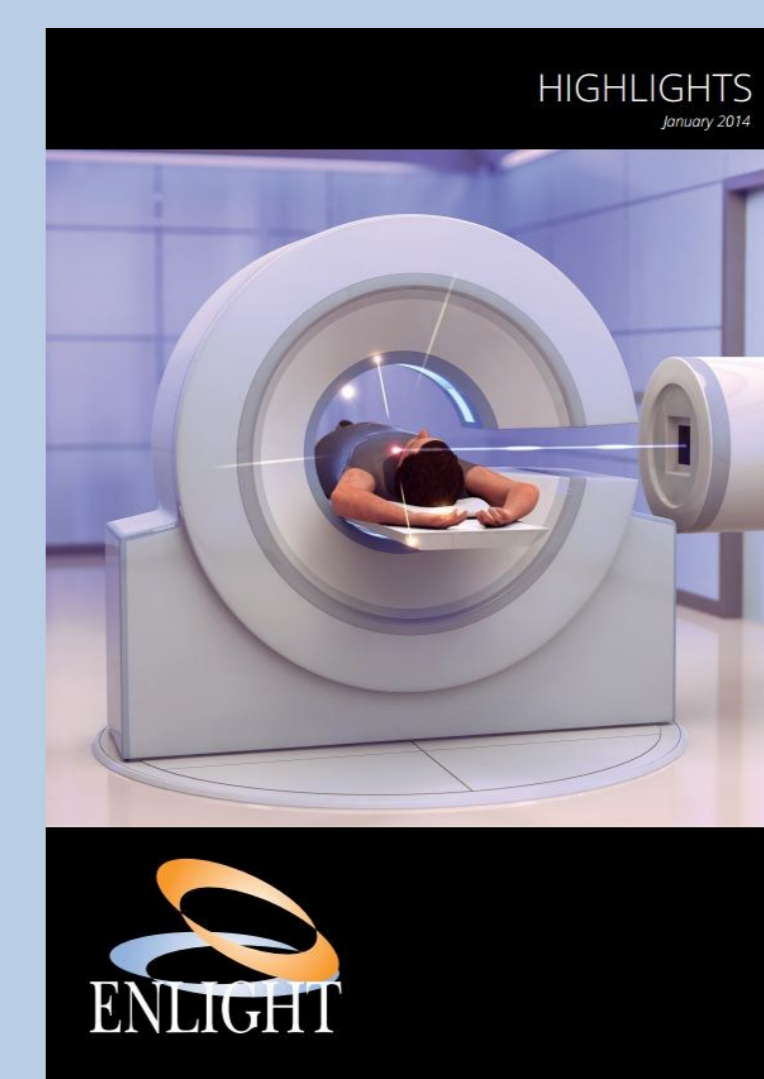

HIT carbon ion gantry, 25 m long, 13 m diameter



Accelerator complex, MedAustron



Treatment room, CNAO

|ARC| AUH,AS| CERN| CNAO| ESTRO| ETOILE| GSI| IBA| IFJPAN| INFN| KI| MEDA| MUW| RUNMC| SAG| TUD| UCL| UKL-HD| UNIMAR| UOXF|



On behalf of the ULICE collaboration

<http://cern.ch/ULICE>